

SIAT

MAILLIS

Carton Sealing Machines

XL46/XL461

SM48/SM481

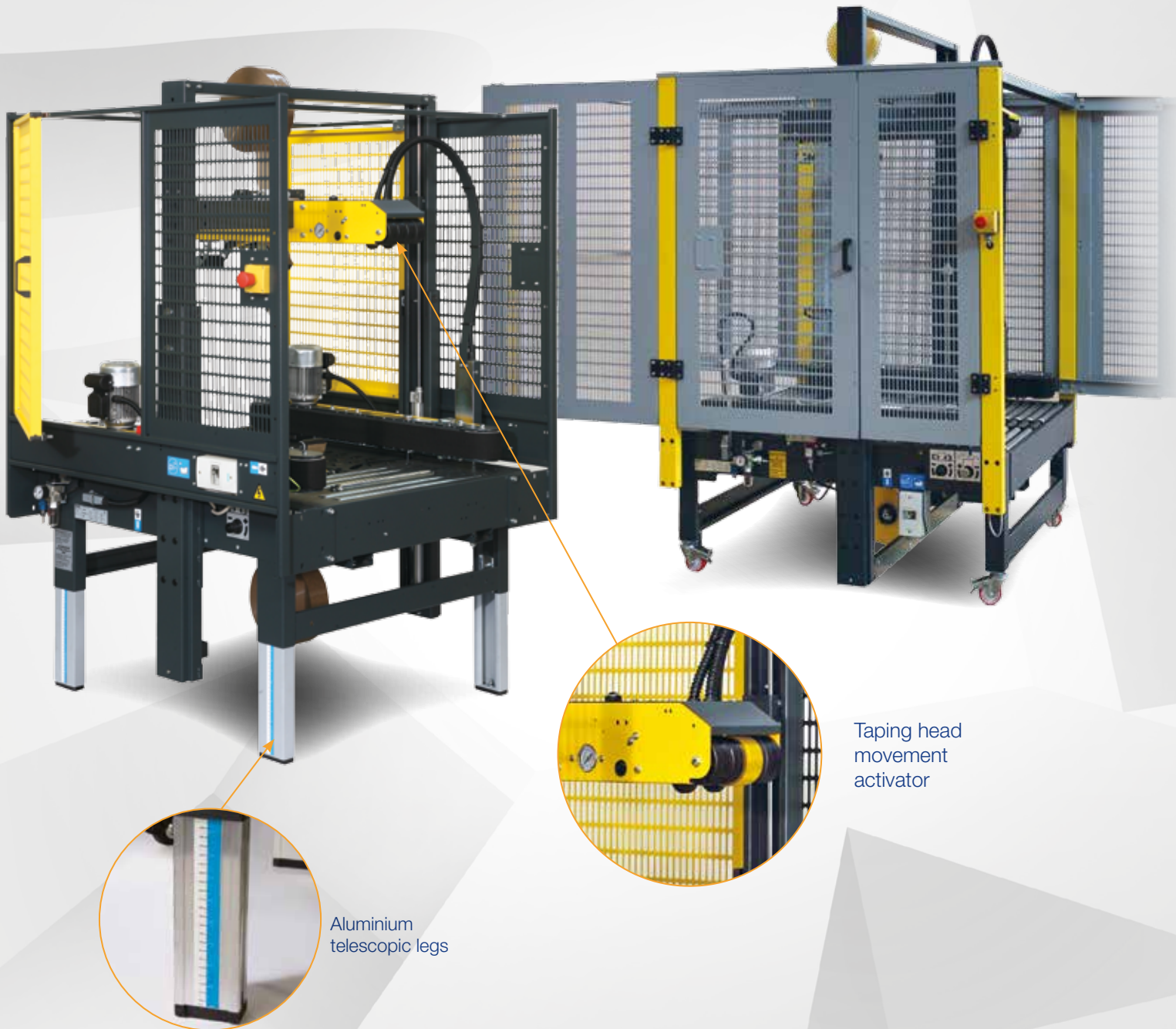

Taping head movement activator

Aluminium telescopic legs

CE

for more details:



XL46



SM48/481

XL46/XL461

XL46 and XL461 are semi-automatic sealing machines with random adjustment.

It means that these machines are able to adjust themselves on the different box dimensions.

The machines are designed to apply automatically a "C" strip of adhesive tape of the top and bottom of boxes.

Machines adjustments and use are intuitive, simple and fast.

On the XL46 version the rest position of the top taping unit is DOWN: the feeding of boxes is performed manually by an operator.

On the XL461 version the rest position of the top taping unit is UP: thanks to some particular devices the feeding of boxes is performed automatically.



Key Features

- Automatic adjustment on different box sizes
- Side lower drive belts (2 x 75 mm width each)
- Drive belts speed 20 m/min.
- 2 x Motors kW 0,13 each
- 2 x K12R taping unit - 75 mm width
- Extruded aluminium telescopic legs with millimetric guide
- Locked stop emergency button
- On/Off magneto-thermic switch
- Adjustable descending height stopper of the top taping unit to increase speed rate
- Top head pneumatic pressure regulators
- Safety protections with switches to disconnect electric & pneumatic circuits if opened
- Adjustable working height 445 - 705 mm

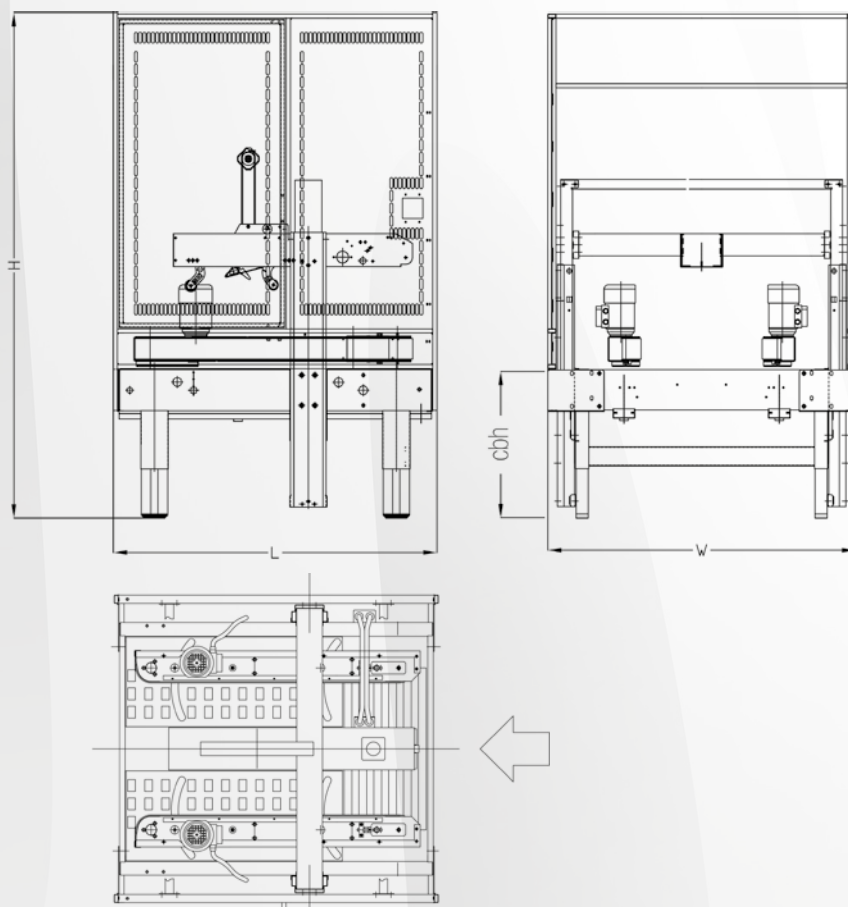

SM48/SM481

SM48 and SM481 are automatic sealing machines with random adjustment.

It means that these machines are able to adjust themselves on the different box dimensions.

Thanks to the top and bottom drive belts and the K12R taping unit, they allow the perfect sealing of the box.

Machines adjustments and use are intuitive, simple and fast.

On the SM48 version the rest position of the top taping unit is DOWN: the feeding of boxes is performed manually by an operator.

On the SM481 version the rest position of the top taping unit is UP: thanks to some particular devices the feeding of boxes is performed automatically.



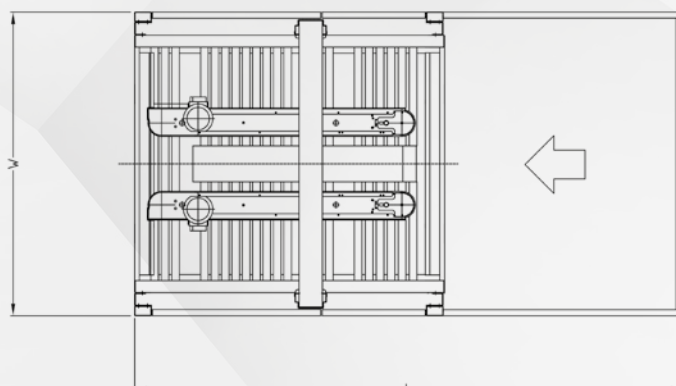
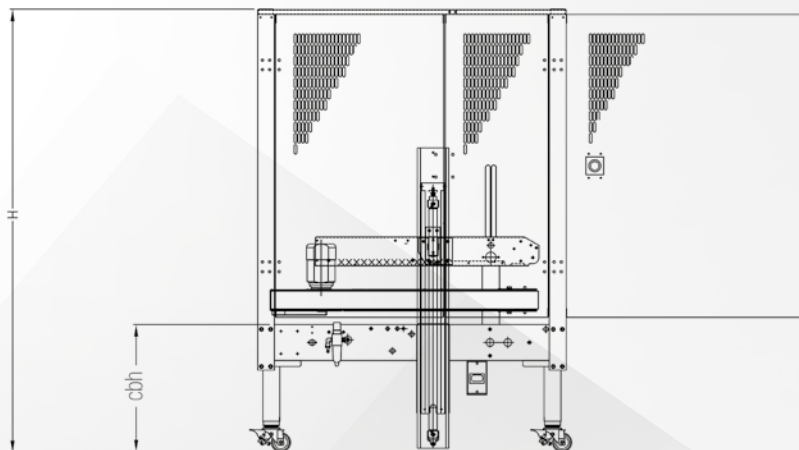

Key Features

- Automatic adjustment on different box sizes
- Side lower drive belts (2 x 75 mm width each)
- Drive belts speed 20 m/min.
- 2 x Motors kW 0,13 each
- 2 x K12R taping unit - 75 mm width
- Extruded aluminium telescopic legs with millimetric guide
- Locked stop emergency button
- On/Off magneto-thermic switch
- Adjustable descending height stopper of the top taping unit to increase speed rate
- Top head pneumatic pressure regulators
- Safety protections with switches to disconnect electric & pneumatic circuits if opened
- Adjustable working height 500 - 750 mm



> **Machine dimensions**
Dimensioni macchina
Machinemessungen
Dimensions machine
Dimensiones de máquina

Size / Weigth packaging			LxWxH 
> XL46 / 461	220	295	125x125x140
> SM48 / 481	220	295	160x160x205

> **XL46 / XL 461**

	Min.	Max
L	1180	-
W	1120	-
H	1490	1750
cbh	445	705
AS 7	545	905
AS 18	645	1025

> **SM48 / SM481**

	Min.	Max
L	2280	-
W	1260	-
H	1740	1890
cbh	430	580
AS 7	530	680
AS 8	630	780

> **Box dimensions**
Dimensioni delle scatole
Kartonabmessungen
Dimensions des boîtes
Dimensiones de cajas

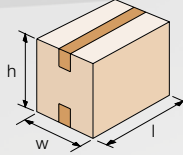

> **XL46 / XL 461**

	K12R std. / K11R on demand	
	Min.	Max
l	150	∞
w	140	650
h	100	650

> **SM48 / SM481**

	K12R	
	Min.	Max
l	200	∞
w	200	800
h	120	800

> **Taping units**
Unità nastranti
Verschliesseinheiten
Unités enrubanueuses
Unidades de precinto

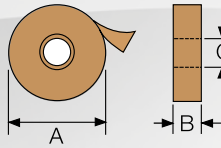

	K11R/ K12R
	mm
A	410 Max
B	50 / 75
C	76

> **Production capacity**
Capacità di produzione
Produktionskapazität
Capacité de production
Capacidad de producción

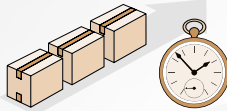

> XL46 / XL 461	Bph
Max pcs.*	600

> SM48 / SM481	Bph
Max pcs.*	600

* Always based on shorter manageable box

> **Air consumption**
Consumo aria
Luftverbrauch
Consommation d'air
Consumo de aire

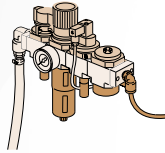

> XL46 / XL 461	NL.
Cycle	12

> SM48 / SM481	NL.
Cycle	14

from 5,5 bar to 7 bar

> **Standard voltage**
Voltaggio standard
Standardspannung
Tension standard
Voltaje estándar

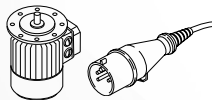

> **XL46 / XL 461**

380/400V - 50Hz - 3F	
440V - 60Hz - 3F	
Amps	1,08
Power kW	0,26
Phase	3Ph + N + PE

> **SM48 / SM481**

380/400V - 50Hz - 3F	
440V - 60Hz - 3F	
Amps	1,08
Power kW	0,26
Phase	3Ph + N + PE

> **Optionals**
Accessori
Zubehör
Accessories
Accesorios

> **AS50**
Higher legs
Set gambe più alte
Höhere Stützen
Pieds plus hauts
Patas más altas



> **AS7**
Casters
Set ruote
Rädchen
Roulettes
Ruedas

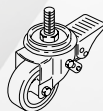

> **RG**
Roller conveyor
Piani a rulli
Rollenbahnen
Plans à rouleaux
Rodillos libres

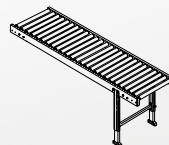

> **GTL - GTR**
Extendable conveyor
Rulliera estensibile
Ausziehbare rollenbahnen
Convoyeur extensible
Rodillos extensibles

