

XL35

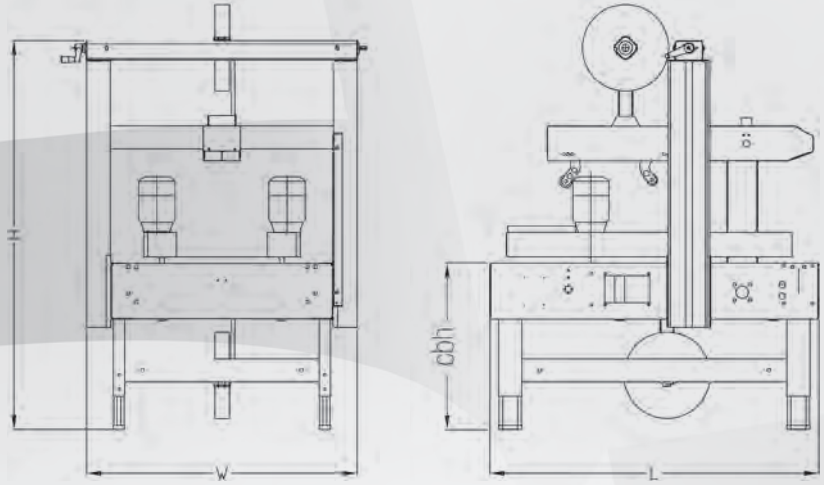

other languages: www.siat.com



> **Machine dimensions**
Dimensioni macchina
Machinemessungen
Dimensions machine
Dimensiones de máquina

Size / Weight packaging			LxWxH
> XL35	185	220	120x106x116

> **XL35**

	Min.	Max
L	938	-
W	1140	-
H	1250	1590
cbh	480	820
AS 77	580	920
AS 80	680	1020

> **Taping units**
Unità nastranti
Verschliesseinheiten
Unitée enrubanneuses
Unidades de precinto

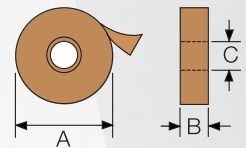

> **Box dimensions**
Dimensioni delle scatole
Kartonabmessungen
Dimensions des boîtes
Dimensiones de cajas

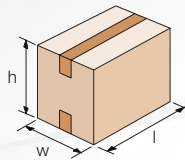

> **XL35**

	K11 / K12	
	Min.	Max
l	150	∞
w	130 / 140	500
h	100	500

> **XL35/4**

	K11	
	Min.	Max
l	150	∞
w	105	500
h	100	500

	K11 / K12	
	mm	
A	410 Max	
B	50 / 75	
C	76	

> **Production capacity**
Capacità di produzione
Produktionskapazität
Capacité de production
Capacidad de producción

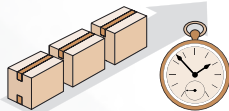

> XL35 - XL35/4	Bph
Max pcs.*	1200

* Depending on operator dexterity

> **Standard voltage**
Voltaggio standard
Standardspannung
Tension standard
Voltaje estándar

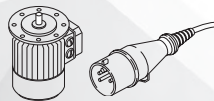

> **XL35 - XL35/4**

380/415V - 50Hz	
<i>Other voltages available on demand</i>	
Amps	1,08
Power kW	0,26
Phase	3Ph + PE

> **Optionals**
Accessori
Zübehor
Accessories
Accesorios

> **AS80**
Higher legs
Set gambe più alte
Höhere Stützen
Pieds plus hauts
Patatas más altas



> **AS77**
Casters
Set ruote
Rädchen
Roulettes
Ruedas

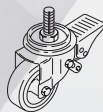

> **RG**
Roller conveyor
Piani a rulli
Rollenbahnen
Plans à rouleaux
Rodillos libres



> **GTL - GTR**
Extendable conveyor
Rulliera estensibile
Ausziehbare rollenbahnen
Convoyeur extensible
Rodillos extensibles

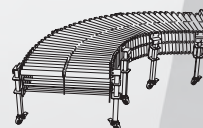

> **K-125 / K-250**
Inkjet printer
Stampante ad inchiostro
Tintenstrahldrucker
Marqueur à jet d'encre
Impresora de inyección de tinta

