

TBS-100 SA H SEAL

SEMI-AUTO TOP AND BOTTOM CASE SEALER



When you require added security to your filled cases, Combi offers a semi-automatic case sealer with an H seal that securely seals both the top and bottom of your case with adhesive tape. The TBS-100 SA H sealers offer a reliable solution for your needs. Using the same heavy duty tubular steel frame as other Combi systems, the TBS is built tough for years of top performance. Six 3M Accuglide™ tape heads firmly seal the top and bottom of RSC and HSC cases.

FEATURES:

- Throughput up to 20 cpm
- Heavy duty tubular steel frame construction with lifetime guarantee
- Top and Bottom C Clip and Edge Seal Combination with 3M Accuglide™ tape heads:
 - Two 2" tapeheads C Clip middle of case
 - Two 2" tapeheads Upper H seal
 - Two 2" tapeheads Lower H seal
- Case transport for standard tape method and 90° transfer for H seal
- Full guarding with hinged doors and safety interlocks
- Single machine application, compact footprint



TBS-100 SA H SEAL

Semi-Automatic Top & Bottom Case Sealer

TBS-100 SA H SEAL

OPTIONS:

- Stainless steel frame with lifetime guarantee
- NEMA 4 compliant water washdown electrical components
- Low tape/No tape alarm system
- 3" (72mm) Accuglide™ tape heads
- Heavy duty locking casters
- Changes to discharge elevation
- Tape application monitoring
- Voltage other than 115V

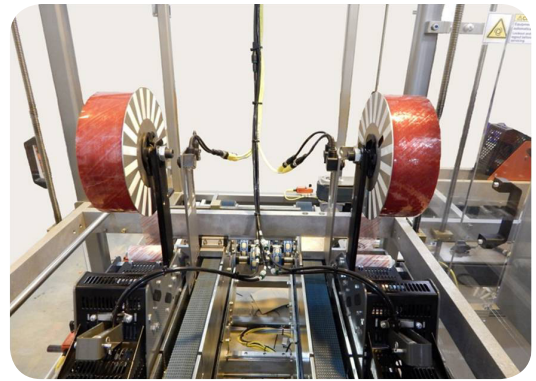

MODEL	CASE SIZE MIN (LXWXH)	CASE SIZE MAX (LXWXH)	SPEED: CPM* ²
TBS-100 SA H	12 x 12 x 4½" (305x305x114mm)	20 x 20 x 20" (508x508x508mm)	20

*Speed is operator and case size dependent

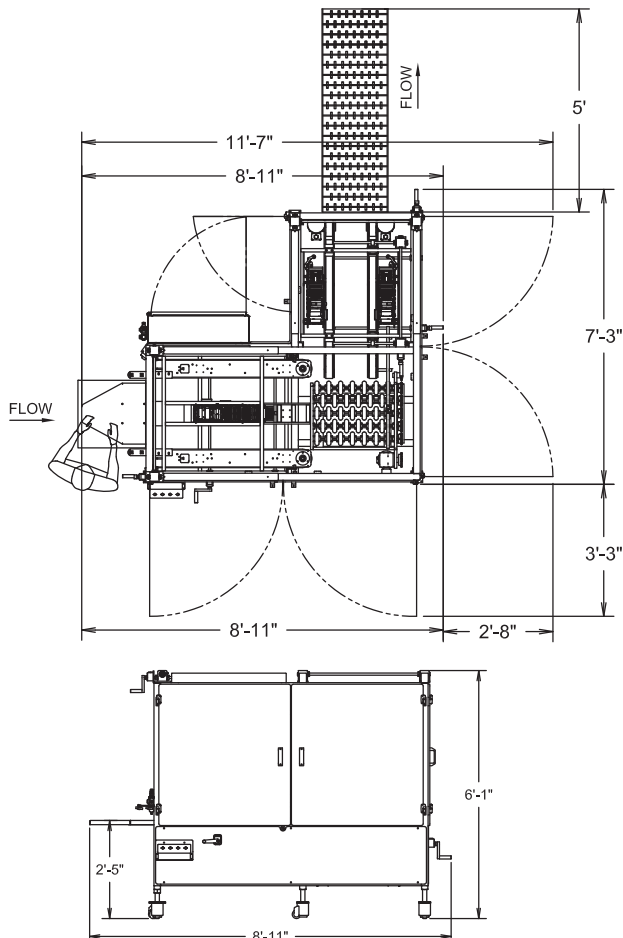

DISTRIBUTED BY:



6299 Dressler Rd NW North Canton, OH 44720 USA
Phone: 1-800-521-9072 www.combi.com

© 2018 Combi Packaging Systems LLC, a joint venture with 3M™ and Maillis Group